

# Bright 315



WiFi-Modul



Doppelte Schweißnaht\*



Verpackt mehrere Produkte gleichzeitig



## Höchste Funktionalität und Zuverlässigkeit!

Exklusive Vakuumkammermaschine aus Edelstahl mit „Automatenstahl“-Vakuumkammer, Doppelschweißung, Anlage zur Inertbegasung, i-Sensor (sensorgesteuertem Vakuumsystem), EASY-System für maximales, auch externes Vakuum.

### Bright 315 Ideal für:



Restaurants



Hotels



Catering



Fleischereien



Käsereien



Lebensmittelwerkstätten

### Verpackungsmethoden:



Nur Versiegelung



Vakuum



Externes Vakuum



MAP

## Koch- und Behälterprogramme inbegriffen:



Fleisch



Huhn



Fisch



Feste Lebensmittel/  
Füllungen



Saucen



Dicke Saucen



Marinaden



Backwaren



Gemüse



Pulver und  
Gewürze



Süßspeisen



Creme-Präparate  
zum Backen



No stop



Behälter sensor



Behälter MIN



Behälter MED



Behälter MAX









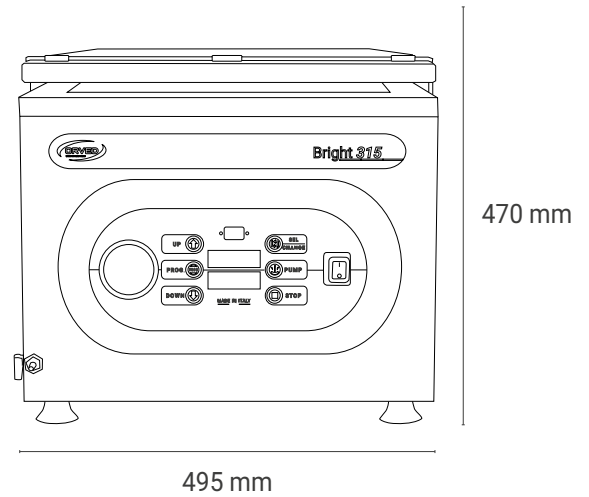

Behälter extreme

## DATENBLATT

- > Maschinenkörper: Edelstahl
- > Außenmaß: 588x587x1025h mm
- > Vakuumkammermaß: 448x440x200h mm
- > Gewicht: 99 kg
- > Spannung: 220-240V 50/60Hz
- > Maximal aufgenommene Leistung: 1200W
- > Abstand Der Balken: 315 mm
- > Vakuumpumpe: 8 mc/h
- > Max. Beutelgröße: 300x350 mm



## Serienausstattung

- |   |   |  |
|---|---|--|
|  Digitales Bedienfeld, 48 Programme            |  Easy, externe Vakuumerzeugung     |  USB-Schnittstelle für Firmware-Updates |
|  Sensorgesteuertes System für absolutes Vakuum |  H2out, Pumpenentfeuchtungsvorgang |  abnehmbarer Gegenhalter                |
|  Doppelte Schweißnaht*                         |  Düse für Behälter                 |  |

## Optional auf anfrage

- |  |   |  |  |
|--|---|--|--|
|  Abtrennung des Beutelüberstands* |  Datumsstempel |  WiFi-Modul |  Kit Glatte Vakuumbbeutel - BASIC |
|--|---|--|--|

## Zubehör

- |   |   |   |  |   |  |   |
|---|---|---|--|---|--|---|
|  Glatte Vakuumpackungsbeutel |  Goffrierte Vakuumpackungsbeutel |  Glatte Vakuumpackungsbeutel |  Unterwagen |  „ConserBox“-Behälter |  „Easy“-Zubehör für externes Vakuum |  Einlegebleche |
|---|---|---|--|---|--|---|